

Vertical Seam – Technical Sheet

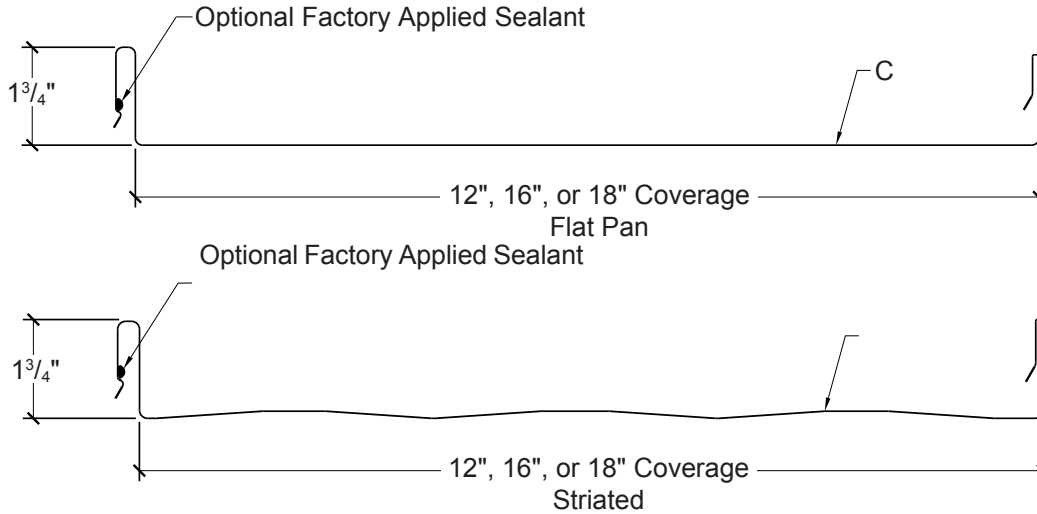

ARCHITECTURAL
COMMERCIAL
PANEL

CONCEALED
FASTENED

12", 16" OR 18"
COVERAGE

MINIMUM
SLOPE
1:12*

OPEN FRAMING OR
SOLID SUBSTRATE

PANEL OVERVIEW

- ▶ Finishes: PVDF (Kynar 500®), MS Colorfast45® and Acrylic Coated Galvalume®
 - ▶ Corrosion Protection: AZ55 per ASTM A 792 for unpainted Galvalume®
AZ50 per ASTM A 792 for painted Galvalume®
G90 per ASTM A 653 for Galvanized
 - ▶ Gauges: 24 ga standard; 26 ga and 22 ga optional
 - ▶ 12", 16" or 18" panel coverage, 1³/₄" rib height
 - ▶ Panel Length: Minimum: 5'; Maximum: 45' recommended
 - ▶ Architectural, structural integral standing seam roof system
 - ▶ Snap-together side lap with factory-applied sealant
- * Minimum roof slope is 1:12 for solid substrates and 3:12 for open framing

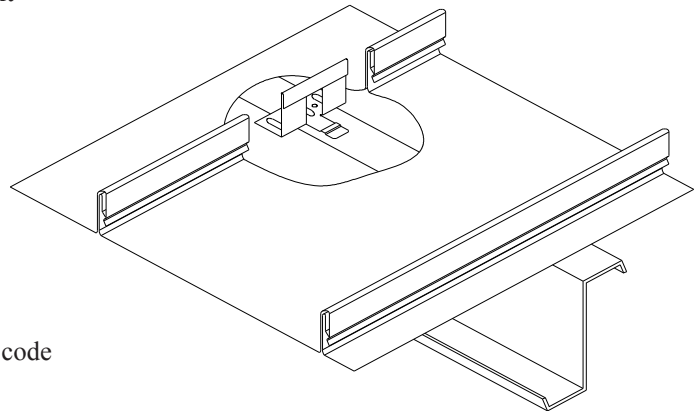

TESTING AND APPROVALS

- ▶ UL 2218 Impact Resistance - Class 4
- ▶ UL 790 Fire Resistance Rating - Class A, per building code
- ▶ UL 263 Fire Resistance Rating - per assembly
- ▶ ASTM E 283 Air Leakage - 0.035 cfm/ft² at 1.57 psf
- ▶ ASTM E 331 Water Penetration - none at 12 psf
- ▶ ASTM E 1680 Air Leakage - 0.0036 cfm/ft² at 6.24 psf
- ▶ ASTM E 1646 Water Penetration - none at 6.24 psf
- ▶ ASTM E 1592 Structural Performance
- ▶ UL 580 Uplift Resistance - Class 90 Constructions: #436, #446 and #448
- ▶ 2010 FBC Approvals - FL11560.9 and FL11560.10
- ▶ Miami-Dade County, Florida NOA 10-0114.04 expires 3/8/2014

Vertical Seam – Technical Sheet

ATTACHMENT DETAIL

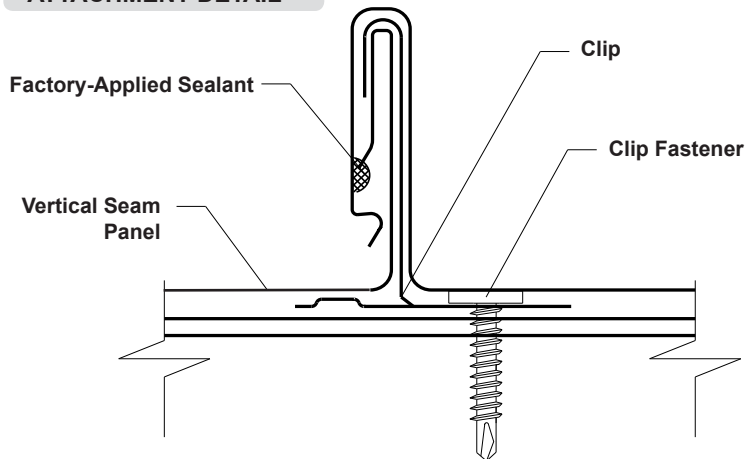

PANEL CLIP

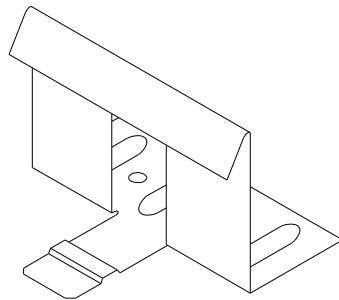

UL90 CLIP
2 Fasteners

FASTENING INFORMATION

► Clips

Clip spacing is based upon the design loads, the spanning capacity of the panels, the fasteners and the support members.

Clips are 0.050" thick. G90 is standard, 304 stainless is optional. 2 fastener holes is standard, 3 holes is optional.

Clips can accommodate practically unlimited thermal movement.

► Fasteners

Overdriven fasteners will cause panel distortions.

Fasteners should extend 1/2" or more past the inside face of the support material.

Clip Fasteners and Concealed End Fasteners:

Attaching to Wood:

#10-12 Pancake Head Wood Screw

Attaching to Steel:

<18 ga: 1/4"-14 Deck Screw

>=18 ga, <=12 ga: #10-16 Pancake Head Drill

Exposed End Fasteners:

Attaching to Wood:

#10-14 Wood Screw

Attaching to Steel:

#12-14 Self Driller

Trim Fasteners:

1/4"-14 x 7/8" XL Stitch Screw

1/8" x 3/16" Pop Rivet

SECTION PROPERTIES

ALLOWABLE UNIFORM LOADS, psf For various clip spacings

Ga	Width in	Yield ksi	Weight psf	Top In Compression		Bottom In Compression		Inward Load						Outward Load					
				Ixx in ⁴ /ft	Sxx in ³ /ft	Ixx in ⁴ /ft	Sxx in ³ /ft	2.5'	3'	3.5'	4'	4.5'	5'	2.5'	3'	3.5'	4'	4.5'	5'
26	12	50	1.06	0.0781	0.0530	0.0377	0.0408	148	104	77	59	-	-	55	49	42	36	-	-
26	16	50	0.97	0.0614	0.0402	0.0283	0.0306	114	79	58	45	-	-	55	49	42	36	-	-
26	18	50	0.94	0.0553	0.0358	0.0253	0.0273	-	-	-	-	-	-	-	-	-	-	-	-
24	12	50	1.38	0.1118	0.0774	0.0533	0.0557	204	143	105	81	64	52	44	43	42	41	40	39
24	16	50	1.26	0.0885	0.0589	0.0398	0.0419	153	107	79	61	48	39	42	38	34	30	27	24
24	18	50	1.22	0.0800	0.0526	0.0353	0.0372	136	95	70	54	43	35	33	30	27	24	20	19
22	12	50	1.81	0.1533	0.1071	0.0773	0.0771	284	198	146	112	89	72	69	67	65	62	60	58
22	16	50	1.66	0.1230	0.0822	0.0585	0.0579	213	149	110	84	66	54	54	51	48	45	36	35
22	18	50	1.60	0.1113	0.0736	0.0520	0.0515	190	132	97	75	59	48	31	30	29	29	28	27

- Theoretical section properties have been calculated per AISI 2007 'North American Specification for the Design of Cold-Formed Steel Structural Members'. Ixx and Sxx are effective section properties for deflection and bending.
- Allowable loads are calculated in accordance with AISI 2007 specifications considering bending, shear, combined bending and shear, deflection and ASTM E 1592 uplift testing for 24 ga and 22 ga and UL 580 uplift testing for 26 ga. Allowable loads consider the 3 or more equal spans condition. Allowable loads do not address web crippling, fasteners or support material. Panel weight is not considered.
- Deflection consideration is limited by a maximum deflection ratio of L/180 of span.
- Allowable loads do not include a 1/3 stress increase for wind.